

DESIGNING MOVEMENT SPACE FOR ELDERLY AND DISABLED PEOPLE IN THE CONSTRUCTION LAW IN SELECTED COUNTRIES

Przemysław Nowakowski, Barbara Gronostajska

Wroclaw University of Science and Technology, Wroclaw, Poland
Faculty of Architecture

ABSTRACT

Background: Building law regulations determine designing the built environment recognising the needs of users of different ages and psychophysical abilities. Seniors and their spatial needs are covered there to a limited extent. The benchmark for design are wheelchair users. Their spatial requirements are greater in relation to independent walkers, including most older people. This makes it difficult to adapt the whole built environment to the needs of people with less mobility dysfunction. This can be considered in terms of spatial design and investment costs. **Material and Methods:** The paper analyses the building regulations of 3 countries in terms of legal conditions to shape the architectural movement space of older people and disabled people. Analytical and comparative methods are used. Such research is becoming relevant and necessary. The analyses are conducted in the context of ageing populations. They are justified by statistical data on the age groups of Polish society. This is followed by design analyses of the legal requirements in the wheelchair movement space and proposals for alternatives, e.g., people walking with canes (case study). Their aim is to indicate methods to limit excessive communication spaces in buildings while maintaining functional values for all users. **Results:** Research may show the possibility of greater diversification of regulations and alternatives to current laws. They are dedicated to participants in investment processes to shape accessible buildings. They can also be used in legislative work on amendments to the construction law. **Conclusions:** Changes in building regulations and a detailed approach to the mobility needs of older and disabled people (walking independently) are proposed. These decisions can provide benefits (spatial and economic savings). They fall into the “design for all” trend and sustainability of the built environment. These demands are based on no longer valid normative regulations. *Med Pr Work Health Saf.* 2024;75(3):189–197

Key words: disabled people, built environment, seniors, architecture, construction law, universal design

Corresponding author: Przemysław Nowakowski, Wroclaw University of Science and Technology, Faculty of Architecture, Prusa 53/55, 50-317 Wroclaw, Polska, e-mail: przemyslaw.nowakowski@pwr.edu.pl
Received: December 28, 2023, accepted: April 24, 2024

INTRODUCTION

Ageing is a constant and inevitable process in human life. It initially results in the growth and development of the body and intellectual abilities in the transition process from childhood to adulthood. Over time, it leads to a decrease in the psychophysical condition with the transition to old age. The artificial human living environment is mainly adapted for the adult population, still a majority able-bodied. The needs of people in different age and ability groups are increasingly and more accurately taken into account in building regulations and investment processes in the built environment. Some public facilities are specially dedicated to, e.g., small children (nurseries, kindergartens) or seniors (sanatoriums, nursing homes). Their design may be supported by more detailed legal and normative guidelines.

Adapting space to the mobility needs of older people and those with various types of disabilities is of particular importance. The share of these people is constantly increasing in the population of modern societies.

MATERIAL AND METHODS

The paper concerns the role of construction law in investment processes, taking into account the spatial needs of the elderly and people with various types of disabilities. The regulations provide the legal basis for shaping the built environment accessible to all users. The research focused on the needs of people with a relatively low degree of motor dysfunction and on the spatial conditions for independent movement, e.g., with the use of a cane or crutches. In the field of construction law, analytical and comparative methods were used. The regulations

applicable in Poland, Germany, and the USA were analyzed and compared. Such research is justified in the context of the ageing of societies and changing legal regulations. They were preceded by research in the literature and a description of the role of seniors in social life and in the economy. The description is a case study. It was supplemented with statistical research on the age groups of the population. National data from the Central Statistical Office were used.

The analysis and comparison of legal spatial requirements for people with various mobility disabilities indicates the needs of people using wheelchairs as the only design criterion. The result of the research is a proposal of alternative solutions for people walking with canes, etc. As a case study, exemplary interior concepts were presented for seniors who walk independently and were later adapted for people in wheelchairs. The main goal of the research is to identify practical and legal methods for reducing communication spaces in buildings while maintaining functional accessibility for all users. Possible changes to the building regulations in force in Poland were suggested based on current and outdated German and American experiences.

The role of older people in society and economy

Old age is traditionally associated with maturity, wisdom, and experience. It is sometimes called as senior age or "third age". It is perceived differently in sciences such as medicine, psychology, sociology, and law. Various criteria are adopted to define old age, depending on the scope of the research. The most common are biological and calendar age (ageing of the body and number of years lived), economic and legal age (working capacity and post-work period) [1].

Technological progress contributes to the improvement of the standard of living of societies in highly developed countries. One of the manifestations of prosperity is a consumer lifestyle and the desire to feel easy comfort, without obligations. People are more likely to avoid lasting relationships, especially having children [2]. On the other hand, good living conditions contribute to extending people's lives. Therefore, unfavourable demographic trends accompany the general development of civilization. Permanent changes in the structure of the human population are already being noticed. In societies, the share of children, young people, and people of prime age, who are often defined as being of working age, is decreasing. At the same time, the proportion of older people aged >60 is increasing. They then retire and cease to be active on the labour market

(post-work age). Older people are often in good psycho-physical condition, which contributes to further extension of their lives. This trend is the result of the prosperity and good living conditions of people for decades and especially the significant advances in medical sciences and techniques.

The decline in the working population and the increase in the number of people receiving retirement benefits are becoming an increasing burden on the budgets of modern countries. In many countries, various efforts are being made to expand the professional activity of older people [3]. There are various systemic proposals, such as the unpopular increase in the retirement age or retirement allowances for long service, that are better accepted by people. This makes it possible to keep seniors on the job longer.

Older people are increasingly willing to face contemporary social challenges. The most important factor for continued professional activity is maintaining or improving the financial situation after retirement. This is indirectly related to acquiring new knowledge and even qualifications, e.g., through self-education or studying at "universities of the third age" (U3A) [4]. Many activities of older people in the work environment are not economically motivated. The place of operation includes, i.e., various social organizations (including charities), as well as companies and institutions employing older volunteers.

Health awareness and prevention are becoming better known and appreciated. Seniors try to be more physically active. They participate more in activities such as outdoor recreation, sports and tourism [5,6]. These are individual actions. There are also social initiatives taken, that is, by housing estate communities and senior clubs. Thanks to them, numerous devices for physical and fitness exercises are placed in recreational areas.

Old age can be considered personally by individual people, as well as on the scale of entire societies. Demographic trends, new needs, and tasks for seniors can be perceived as a design task in shaping the built environment on the urban and building scale. The elderly are also becoming an increasingly larger and more influential consumer group in the economy. Their specific needs should be increasingly better recognized and realized in various spheres of everyday life, as well as in the space designs of modern cities.

Old age and disability

Older people (60 years or older) constitute just >25% of Polish society, including 14% of people aged 60–69 years. In this group, 18% of people are profes-

sionally active. Statistics also indicate that approx. 13% of people are considered disabled. The percentage of disabled people increases with age. Among people 60–69 years, about 35% consider themselves disabled, and those 70–79 years – 44% [7]. Disability may be of a varied nature. It can be linked not only to health and fitness factors but also to social factors (interpersonal relationships, professional work, etc.). It does not always have to involve a reduction in people's mobility. The share of older people in the Polish population and general demographic trends indicate a further increase in the number of disabled people and their percentage share in society in the future.

Physical fitness of older people

Human physical activity accompanies the fulfilment of various life needs. It covers all daily activities and tasks. The most important include, i.e., maintaining body hygiene and condition, preparing and eating meals, housework, learning and studying, gainful employment, relaxation, and entertainment. Social life and interpersonal contacts also require moving around and even changing one's place of residence.

Old age is revealed, i.e., in morphological and biochemical changes of the body, reduced resistance to physical, mental and social stress, and susceptibility to diseases. It leads to permanent disability and even incapacity (loss of independence in daily activities) [8].

Temporary or permanent deterioration of physical and mental health can be considered as disability in the architectural sense (human-space relations). Strong and long-lasting factors that cause a decrease in the psychophysical condition of the human body lead to a decrease in mobility. The consequence is a change in the scale of the accessible built environment. In this case, the range of independent movement is reduced.

Classification of persons with reduced mobility

Reduced mobility of the human body manifests itself, that is, by a limited ability to move from place to place due to musculoskeletal dysfunctions. Freedom of movement is also impaired by limited grasp and reach of the arms and hands, as well as visual dysfunctions.

According to the Polish Central Statistical Office, almost 13% of adults indicated difficulties moving in flat terrain and 15% had difficulties walking up stairs. These were mainly older people, >70% [7]. In such a situation, mobility disability does not exclude the ability to walk independently, possibly with the help of, e.g., a cane or crutches.

The number of people with mobility impairments is just >1 million people, which is approx. 3% of the population. Most of them are wheelchair users. More and more modern wheelchairs enable easier mobility [9]. This makes it possible to perform daily physical activities independently. Elderly and generally disabled people can have temporary or permanent mobility impairments of varying degrees of severity. In the built environment, these people are as follows:

- able to walk without assistance (limitations in movement result from, e.g., old age, amputation of limbs “replaced” with prostheses);
- walking with the use of a cane, crutches, walkers (limitations of movement are, e.g., due to old age, joint diseases, amputation of limbs, etc.);
- manual powered wheelchair users (able to walk short distances, often using crutches, canes, walkers);
- manual wheelchair users (having complete dysfunction of the lower extremities but fully functional trunk and upper extremities);
- electric wheelchair users (having complete dysfunction of the lower extremities and significant dysfunction of the trunk and upper extremities).

The architectural design of movement spaces and individual functional zones should take into account the mobility capabilities of most able-bodied people, but also disabled people, including independent walkers, those who walk with the help of crutches, and those in wheelchairs.

Elderly people at home and work

The increasing share of older people in the population of developed countries is called ageing populations. This process is a challenge for the creators of the contemporary built environment, including architects and urban planners. The traditional “design for the disabled” recognized the specific needs of handicapped people. They were related to the spatial conditions of wheelchair use. The currently recommended “universal design” already takes into account the needs of all users, regardless of age and psychophysical condition (including older people and people with various disabilities, not only motor disabilities). Removing architectural barriers and ensuring accessibility are also undertaken in legislative and design activities. It still applies to urban spaces and selected groups of buildings. In the latter case, it mainly concerns residential architecture and health care facilities. Concern for the standard of housing and access to health care for disabled people, especially the elderly, is still seen in the context of the state care system and the social benefit system.

Taking into account the growing social (including professional work) activation of older people and people with various disabilities, adaptive measures should also be taken in the broadly understood work environment. These people may find employment, e.g., in various service sectors, cultural institutions, tourism, etc. Meeting these demands requires creating a “space of accessibility” in the entire built environment. Systemic activities in architecture and urban planning, combined with legal and economic conditions, are necessary.

Spatial design for elderly and disabled people in construction law in selected countries

The design of the built environment is regulated by law in individual countries. The regulations are more general and detailed. They are amended every few years. The purpose of the changes is to adapt them to current social requirements and international agreements. The state of the law reflects the current social and technical development. It is important to ensure equal opportunities for all participants of social life and their participation in the architectural space.

Building regulations in Poland

The construction land the implementing regulations were significantly changed and adopted in 1994. Since then, they have been amended several times. They are still valid in their basic form to this day.

The Building Act is superior (last amendment in 2023) [10]. In >100 articles, it defines the conditions for conducting construction investments and the tasks of participants in these processes. It also indicates the need to specify the minimum share of residential premises accessible to disabled people, including older people, in the total number of dwellings in a multifamily building [10]. The provisions of the Convention on the Rights of Persons with Disabilities, enacted at the United Nations on 13 December 2006, were recalled (in Poland it was incorporated into an act in 2012) [10,11]. The building regulations also discuss general technical facilities for disabled people, such as ramps for wheelchair users, as well as the need to describe in building designs the conditions necessary for the use of the building by these persons and the need to control the implementation of these provisions at the investment site.

More detailed design and technical provisions are included in the Regulation of the Minister of Infrastructure on the technical conditions to be met by buildings and their location (last amendment in 2022) [12]. More than 330 paragraphs specify the technical conditions for the

design, construction, and operation of buildings and the conditions for their location. More than 40 paragraphs or parts there of (paragraphs) concern architectural barrier-free design. Elderly people are only mentioned twice in the context of staircase design and building fire safety. The spatial and technical facilities for wheelchair users are developed in more detail. Generally, the following topics are discussed: parking lots and garbage bins, recreational areas, gates and fences, access to buildings and apartments, elevators and staircases, ramps, hygiene and sanitary rooms, windows and doors, alarm, call installations and systems. The indicated functional zones are located in almost all types of public accessible buildings (including services and workplaces). More specific recommendations concern the leisure environment – residential architecture. In multifamily residential buildings that are not equipped with elevators, there should be ramps or technical devices that allow disabled people to access apartments located on the first floor above the ground floor. On the other hand, in multifamily residential buildings, collective residences and public buildings equipped with lifts, disabled people should have access from the ground level and access to all usable floors [12]. It should be noted that the location of the first stop on the top floor of a residential house makes the staircase inaccessible to people using wheelchairs. This solution is often found, especially in older buildings built with large-panel technology.

In design practice, wheelchair access to each functional area can be provided by a clear accessible route of min. 120 cm and at least 1 full turning (manoeuvring) space for a wheelchair in square form of 150 × 150 cm (Figure 1a and 1b) [13]. These requirements are consistent with normative provisions, i.e., in other European Union (EU) countries.

In the case of Polish residential buildings, workplaces and interiors themselves, there is a lack of definition of rules and design standards on minimum conditions of movement and use of various functional zones by seniors and disabled people who walk independently (the principle “design for all”). The rules apply only to wheelchair users.

Building regulations in Germany

The structure of the building regulations in Germany is similar to that of Poland. It may be due to similar social conditions in both countries, including cultural and climatic conditions. These provisions may also have been a model for Polish legislation during our country's preparations for accession to the EU in 2004.

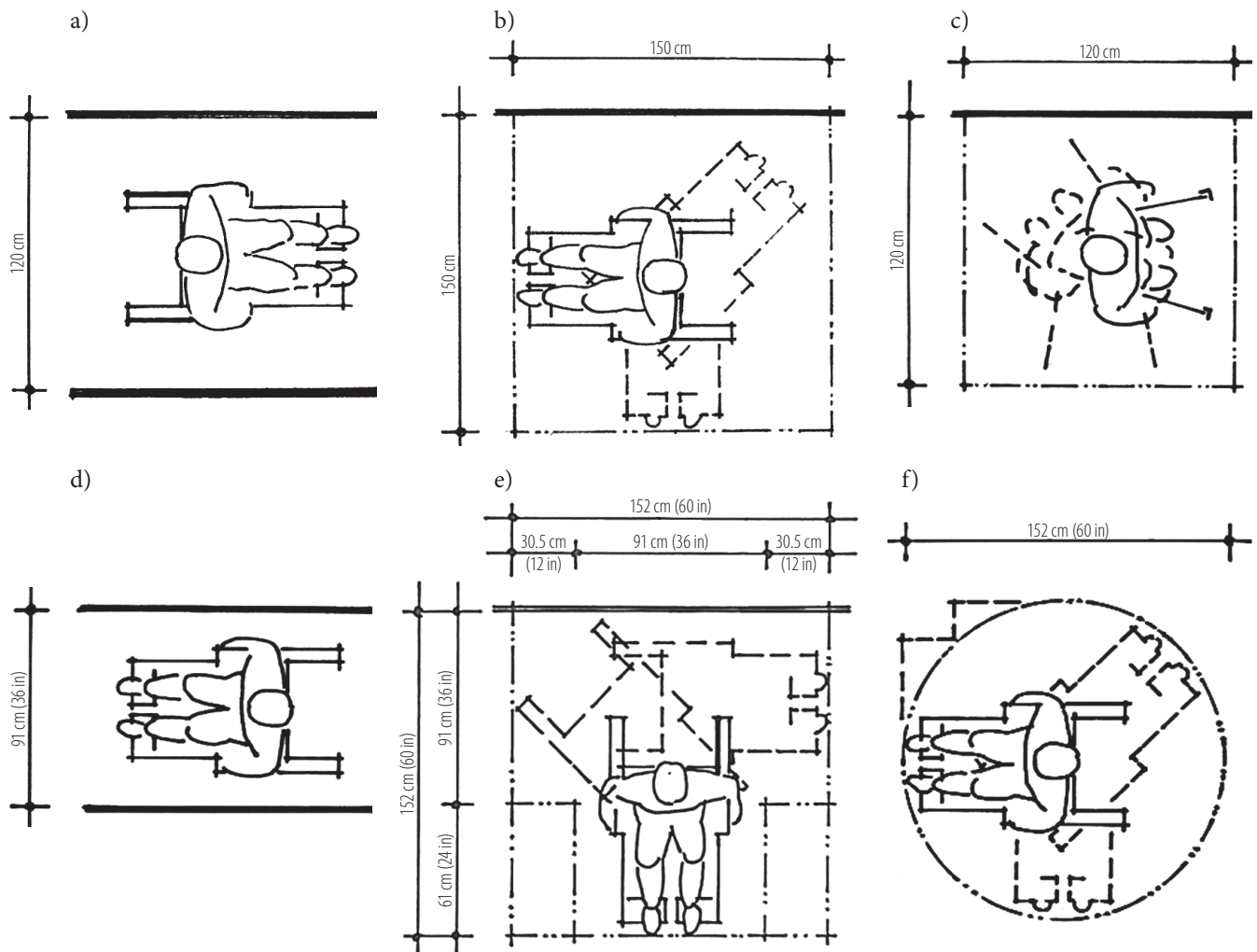

In the original American regulations the values were given in inches, but for the purposes of this article they were converted to centimeters.

Figure 1. Maneuvering space for people with mobility impairments: a) clear width of an accessible route, b) a wheelchair turning space (according to Polish [12,13] and German [15] regulations), c) maneuvering space for a person walking on crutches (according to the outdated German DIN 18025-2 standard) [16], d) clear width of an accessible route, and e), f) wheelchair turning space (according to American regulations) [19]

The Building Act (*Bauordnungsrecht*) is almost uniform throughout the Federal Republic, but has been adopted separately for the individual states (*Länder*) [14]. One paragraph defines “special groups of the population”: the sick, disabled people with canes and wheelchairs, the elderly, people with strollers, and those with small children. Buildings are required to be accessible without the use of third-party assistance. Types of buildings with a communication system ensuring access for “special groups of people” are indicated: shops, cinemas, theatres, museums, restaurants, religious buildings, sports facilities, office and administrative facilities, railway stations, banks, and libraries. Buildings that should be fully accessible are also distinguished: hospitals, clinics, sanatoriums, education or work for disabled people, residential and care homes [14]. Therefore,

the different types of accessible buildings are accurately indicated. They are not limited to residential architecture. Specific facilities with service functions and those characteristic of the work environment are mentioned. Functional spaces for “special populations” are also distinguished: parking spaces for cars, accesses to buildings and dwellings, elevators and staircases, hygiene and sanitary rooms, etc. These zones are the same as in the Polish regulation on technical conditions.

Building regulations for the design of movement spaces for wheelchair users are developed and illustrated in detail in 3 German Industry Standards, DIN 18040-1, 2, 3. Standards apply to publicly accessible buildings, dwellings, public transport, and open spaces [15]. They indicate recommendations for the planning of outdoor facilities, public and residential buildings, residential interiors that

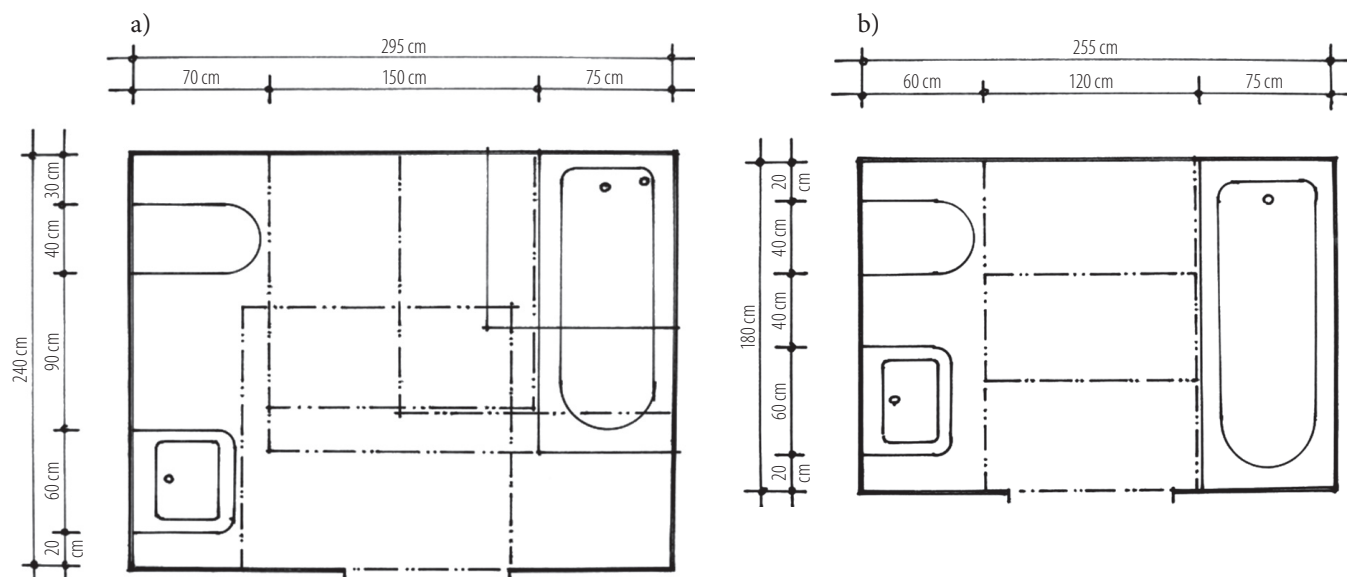

Figure 2. Free maneuvering space in the bathroom: a) for a person in a wheelchair according to Polish [12,13] and German [15] regulations, b) for a person walking on crutches according to the outdated German DIN 18025-2 standard [16]

can be used without architectural barriers and without restrictions in moving around in a wheelchair. Normative access to functional zones must be provided by a clear accessible route of min. 120 cm and a square turning space of 150 cm (Figure 1a and 1b).

The 3 parts of standard DIN 18040 cover almost all types of movement spaces in the built environment. They replaced the now outdated 2-part standard DIN 18025-1, 2 entitled “Barrier-free housing”. Its second part defined a smaller space for older people and disabled people with limited walking ability [16]. This referred to people moving with a cane, crutches, walkers, etc. The use of such equipment does not require as much additional space as is needed for wheelchair users. The standard assumes the turning space for people walking, e.g., with a cane or crutches, in the form of a square of 120 × 120 cm (Figure 1c).

This former provision allowed for a more space-efficient interior design of residential buildings. It was possible to legally implement functional and spatial projects with a smaller communication area compared to wheelchair-user facilities (Figure 2a and 2b).

Building regulations in the USA

The USA has a comprehensive and quite detailed National Building Code. There is only one chapter in the act that concerns accessibility to buildings for wheelchair users. As in the Polish regulation, the same spaces in the built environment are discussed (car parking spaces, access to buildings, lifts and staircases, ramps, etc.). The statutory provisions are also of a general nature.

More detailed recommendations are presented by The Americans with Disabilities Act (ADA) and the American National Standard – Accessible and Usable Buildings and Facilities developed by the US Department of Housing and Urban Development and published by the Department of Justice [17–19]. The regulations are very detailed and are supplemented by numerous graphic diagrams. Among others, the following zones are discussed: public spaces, multi-story buildings, health and care facilities, residential and temporary housing, rehabilitation and penitentiary facilities, amusement parks, sports areas and facilities, playgrounds, kitchens, toilets and bathrooms, work areas, automated teller machines (ATMs), fuel dispensers, etc., windows and doors, passageways and ramps, stairs, lifts, platforms and hoists, bathroom fittings, handrails, alarm systems, visual, tactile, and acoustic markings, means of transport, exercise equipment, park benches, human body dimensions and mobility areas, reach and grab zones, additional facilities for wheelchair users.

The graphic diagrams show in detail the recommended forms of landscaping in open spaces and interior furnishings in relation to blind people walking with a cane and using wheelchairs. Wheelchair users must have access to each functional area by means of a clear accessible route of min. 36 in (approx. 91.5 cm) and a full wheelchair turning area of min. 60 in (approx. 152 cm) or a T-shaped maneuvering area contained within a square with a diameter of min. 60 × 60 in (Figure 1d and 1e). In American law, the space requirements for wheelchair users are therefore much smaller than in Poland and Germany. For example, the inclusion of the wheelchair

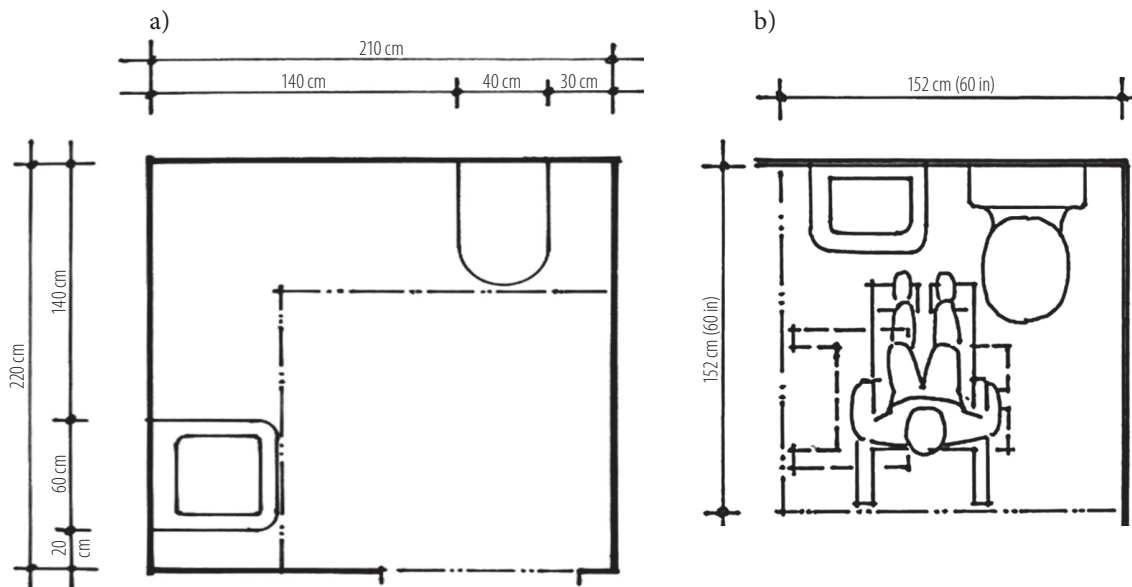

In the original American regulations the values were given in inches, but for the purposes of this article they were converted to centimeters.

Figure 3. Wheelchair turning space in the restroom according to a) Polish [12,13] and German [15] regulations, b) American regulations [19]

turning space in a 150 cm diameter circle allows for easier design of small rooms. The circular outline allows one to free up floor space in the corners of the room, e.g., for a chimney or an installation riser (Figure 1f). There are also more liberal recommendations that allow fixtures, e.g., wash basins and WC, to be placed in the wheelchair rotation area (diameter approx. 152 cm) [19]. Furthermore, positioning the washing basin next to the toilet allows smaller usable restroom areas to be designed (Figure 3a and 3b). Similar concepts are commonly implemented in public restrooms in the USA. However, they limit the freedom to manoeuvre and transfer from the wheelchair to the toilet and vice versa (e.g., sideways).

Movement spaces for elderly and people with various types of disabilities – alternative design concepts

The term “accessibility” refers to the specific needs of wheelchair users. Fulfilling them requires designing the largest movement spaces. However, “accessibility” represents lower mobility requirements. This affects larger groups of people, such as elderly people who walk independently, people with canes and crutches, deaf and blind people. The lack of standardized, cost-saving spatial recommendations for these people most likely takes into account the further probable deterioration of their psychophysical condition and the end state, wheelchair use. Older people with such deteriorating health are no longer independent. They cease to be professionally active and independent in everyday life.

Designing movement spaces according to wheelchair accessibility criteria is in line with the concept of “universal design.” Its goal is to adapt the entire artificial human living environment to the needs of all users, regardless of age and psychophysical condition. It should take into account possible benefits for non-disabled people, who make up the majority of population. Prointegration spatial concepts, especially in terms of removing architectural barriers, are accepted by most people as tangible amenities in everyday life. However, they require a forward-looking design of movement space with a larger space reserve, which will rarely be used by potential wheelchair users.

An alternative design to the current regulations appears to be more economically rational and easier to carry out throughout the investment process. Ergonomic experience can be used, as well as the currently no longer applicable recommendations from the DIN 18025-2 standard, which took into account the weaker ability to walk independently (Figure 4). This postulate may particularly apply to modernized buildings (including historic ones) that were not originally adapted to the specific needs of people with disabilities.

RESULTS

Research in the literature has identified a significant social and economic role for older people. This role falls within the concept of “universal design” in the built environment. Statistical analyses have confirmed the ageing of the society in Poland and the increasing proportion of seniors in the population.

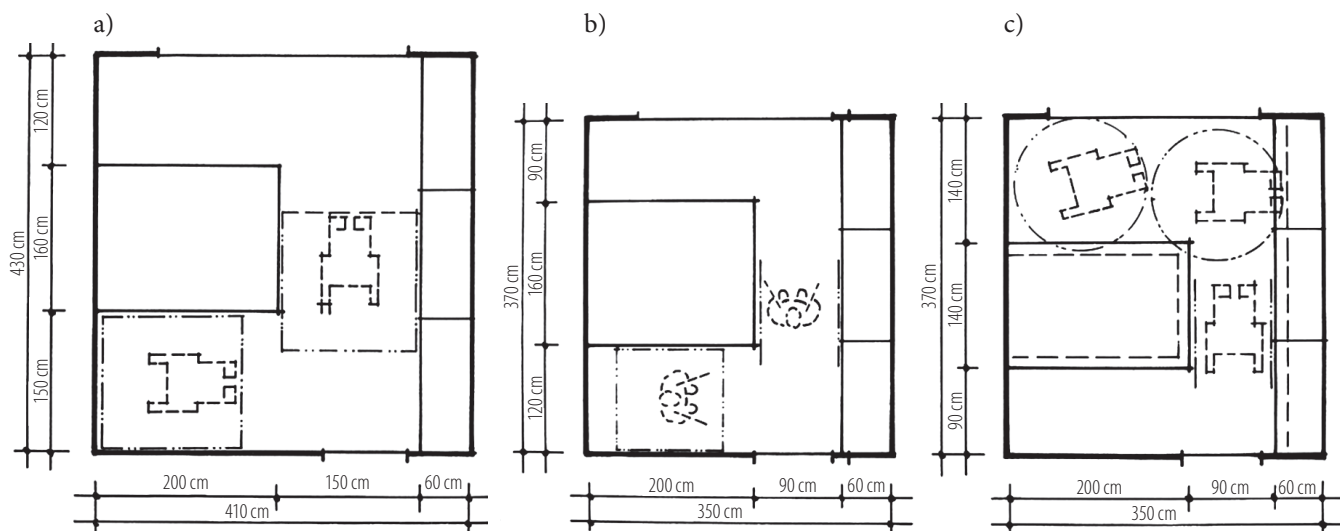

Figure 4. Authors' plan of a double bedroom: a) for a wheelchair user according to Polish [12,13] and German [15] regulations, b) for a person walking independently on crutches according to the outdated German DIN 18025-2 standard [16], c) adapted for a person using a wheelchair according to American standards [19]

This paper presents the structure and content of building regulations in selected countries. The legal recommendations on the size of the movement spaces for disabled people were compared. In all cases, the similarity of the specific provisions with application in design practice is noted. The provisions on the permissible use of smaller movement spaces for people who still walk independently may be questionable. It seems that adapting these spaces to the new needs of wheelchair users will be impossible. Therefore, the accessibility criterion to the target in the built environment is used for them.

DISCUSSION

Statistics showed that wheelchair users are a small group of the population. People who walk independently (including seniors) are a more numerous group of disabled people. This should be incorporated into legal regulations and design practice that cover the entire built environment.

In some buildings and accessible interiors, it is enough to provide smaller maneuvering space for people walking, e.g., on crutches (120 cm square). In the "universal design" trend, it is recommended to reinstate the currently no longer applicable provisions of the German DIN standard, in addition to the current regulations. As part of subsequent adaptation works, such a space can often be transformed into a wheelchair accessible space (150 cm square). Expanding it by 30 cm in each direction may be possible, e.g., by rearranging functional areas or adjusting the forms of furniture equipment (Figure 4).

Sometimes, it will be necessary to use the free space under the furniture to accommodate the feet (or even knees) of a person sitting in a wheelchair [20]. This concept is inconsistent with current Polish and German regulations but is permissible in the USA. Technically, it is possible and fits the body dimensions of a person sitting in a wheelchair. Therefore, the American legal experience regarding the size of the movement space for wheelchair users may be an alternative to the demanding regulations in Poland and Germany.

CONCLUSIONS

An analysis of the construction laws in selected countries showed a similarity in the general design recommendations in creating a built environment for all users. In this respect, the detailed regulations in the USA are the most liberal.

For the specific movement needs of people with disabilities, only wheelchair conditions are included in the regulations. These people need the largest spaces. The correct design of functional-spatial layouts of different buildings is difficult, and sometimes even conflicts with other legal recommendations. The use of mixed-plane circulation spaces can be a great help in design and investment processes. Only part of the space can be dedicated to wheelchair users. Other parts can only take into account the needs of disabled independent walkers. However, in doing so, it is necessary to provide technical means for their future transformation and adaptation to the increasing mobility needs of wheelchair users.

Author contributions

Research concept: Przemysław Nowakowski, Barbara Gronostajska

Research methodology: Barbara Gronostajska, Przemysław Nowakowski

Collecting material: Przemysław Nowakowski, Barbara Gronostajska

Statistical analysis: Barbara Gronostajska, Przemysław Nowakowski

Interpretation of results: Barbara Gronostajska, Przemysław Nowakowski

References: Przemysław Nowakowski, Barbara Gronostajska

REFERENCES

1. Duda K. Proces starzenia się. In: Marchewka A, Dąbrowski Z, Żołądź JA, editors. *Fizjologia starzenia się. Profilaktyka i rehabilitacja*. Warszawa: Wydawnictwo Naukowe PWN; 2013. p. 4–5.
2. Cieślińska B. Bezdzietność jako styl życia. In: Żelazny W, Biłous M, editors. *Pogranicze. Studia Społeczne*. Białystok: Instytut Socjologii Uniwersytet w Białymstoku; 2014; Vol. XXIV. p. 287.
3. Dązbłaż B. Z aktywnością zawodową seniorów nie jest źle, ale mogłoby być lepiej. *Prawo.pl* [Internet]. 2022 [cited 2023 Sept 15]. Available from: <https://www.prawo.pl/kadry/aktywnosc-zawodowa-seniorow-jak-ja-wydluzyt-mrips,514486.html>.
4. Centralny Instytut Ochrony Pracy – Państwowy Instytut Badawczy [Internet]. Warszawa; 2023 [cited 2023 Sept 15]. Łastowiecka-Moras E, Bugajska J. Działania przedłużające aktywność zawodową pracowników starszych. Available from: https://www.ciop.pl/CIOPortalWAR/appmanager/ciop/pl?_nfpb=true&_pageLabel=P30001831335539182278&html_tresc_root_id=21878&html_tresc_id=26170&html_klucz=19558&html_klucz_spis=.
5. Hill RD. *Pozytywne starzenie się*. Warszawa: Laurum; 2009. p. 181.
6. Rowiński R, Dąbrowski A. Aktywność fizyczna Polaków w wieku podeszłym. In: *Polityka Społeczna*. Warszawa: Ministerstwo Rodziny i Polityki Społecznej; 2011(4). p. 45–52.
7. *Analizy statystyczne. Stan zdrowia ludności Polski w 2019 r.* Warszawa: Główny Urząd Statystyczny; 2021. p. 21,65.
8. Janocha A. Proces starzenia się mózgu a funkcjonowanie poznawcze. In: Bortkiewicz A, Borodulin-Nadzieja L, et al., editors. *Proceedings of the 1st National Conference: Ergonomics of Elderly Age*; 2022 Sep 24; Wrocław: Komisja Ergonomii Wieku Podeszłego, Polska Akademia Nauk Oddział we Wrocławiu; 2002. p. 21–24.
9. *Niepełnosprawni w Polsce* [Internet]. Łódź: Mobilex Sp. z o.o.; 2023 [cited 2023 Sept 15]. Available from: <https://www.mobilex.pl/blog/niepelnospawni-w-polsce/>.
10. Ustawa z dnia 7 lipca 1994 r. Prawo budowlane. *DzU z 1994 r., nr 89, poz. 414*.
11. Konwencja ONZ o prawach osób niepełnosprawnych. *DzU z 2012 r., poz. 1169*.
12. Rozporządzenie Ministra Infrastruktury z dnia 15 kwietnia 2022 r. w sprawie warunków technicznych, jakim powinny odpowiadać budynki i ich usytuowanie. *DzU z 2022, poz. 1225*.
13. Kowalski K. *Projektowanie bez barier – wytyczne*. Warszawa: Stowarzyszenie Przyjaciół Integracji; 2022. p. 6.
14. Bayerische Bauordnungsrecht [Internet]. Munich: Bayerisches Staatsministerium für Wohnen, Bau und Verkehr; 2023 [cited 2023 Sept 20]. Available from: <https://www.gesetze-bayern.de/Content/Document/BayBO>.
15. Norma DIN 18040-1: Öffentlich zugängliche Gebäude, DIN 18040-2: Wohnungen, DIN 18040-3: Öffentlicher Verkehrs- und Freiraum [Internet]. Berlin: HyperJoint GmbH; 2023 [cited 2016 Mar 1]. Available from: <https://nullbarriere.de>.
16. Norma DIN 18025-2 Barrierefreie Wohnungen [Internet]. Berlin; 2023 [cited 2016 Mar 1]. Available from: <https://nullbarriere.de/din18025.htm>.
17. Patterson T. *Illustrated 2000 Building Code Handbook*. New York: McGraw-Hill; 2001.
18. The Americans with Disabilities Act – ADA [Internet]. Washington DC: U.S. Department of Justice; 2023 [cited 2023 Sept 20]. Available from: <https://www.ada.gov>.
19. American National Standard, Accessible and Usable Buildings and Facilities. Washington DC: International Code Council; 1998. p. 8,13.
20. Loeschke G, Pourat D. *Integrativ und barrierefrei. Behindertengerechte Architektur für Hochschulen und Wohnheime*. Darmstadt: Das Beispiel; 1994. p. 215.